



**ATTENZIONE:** leggere

l'installazione deve essere eseguita da personale qualificato e abilitato;  
è necessario rispettare le norme e le disposizioni di legge in fatto di sicurezza;  
è necessario rispettare le disposizioni di installazione e manutenzione riportate sul presente manuale;  
le istruzioni costituiscono parte integrante del prodotto pertanto deve essere conservato;  
questo prodotto può essere destinato solo all'uso per il quale è stato progettato;

**NON UTILIZZARE APPARECCHI ELETTRICI ALL'INTERNO DELLA CABINA**

**ATTENTION:** read and follow all instructions

installation should be performed by qualified personnel;  
it is necessary to follow all security norms and laws;  
it is necessary to follow installation and maintenance instructions presented in this manual;  
the instructions form the integral part of the product and therefore they should be preserved;  
this product should be used with the scope for which it was developed.

**DO NOT USE ELECTRICAL DEVICES INSIDE OF THE CABINE**

**Componenti per l'installazione**  
**Components for the installation**

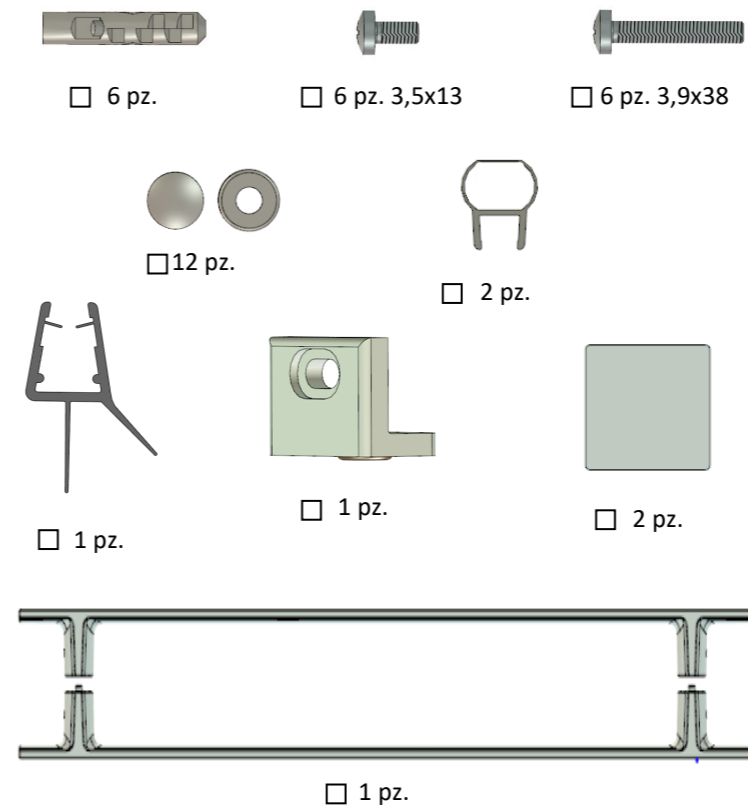

IMMAGINI INSERITE A SOLO SCOPO ILLUSTRATIVO  
IMAGES INSERTED FOR ILLUSTRATIVE PURPOSES ONLY

**Utensili per l'installazione**  
**Tools for the installation**

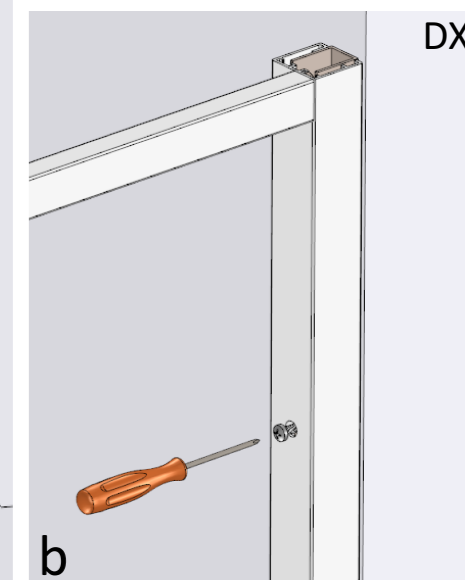
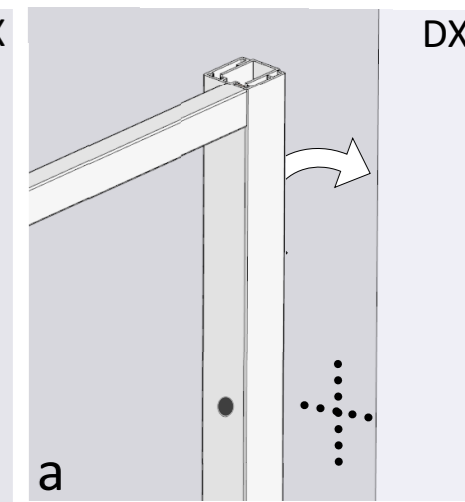
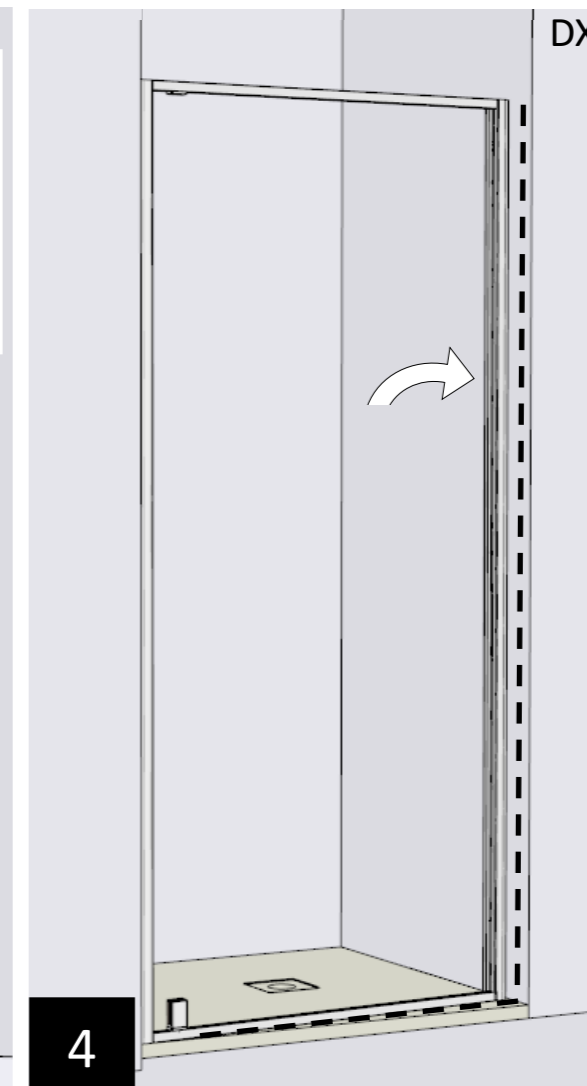
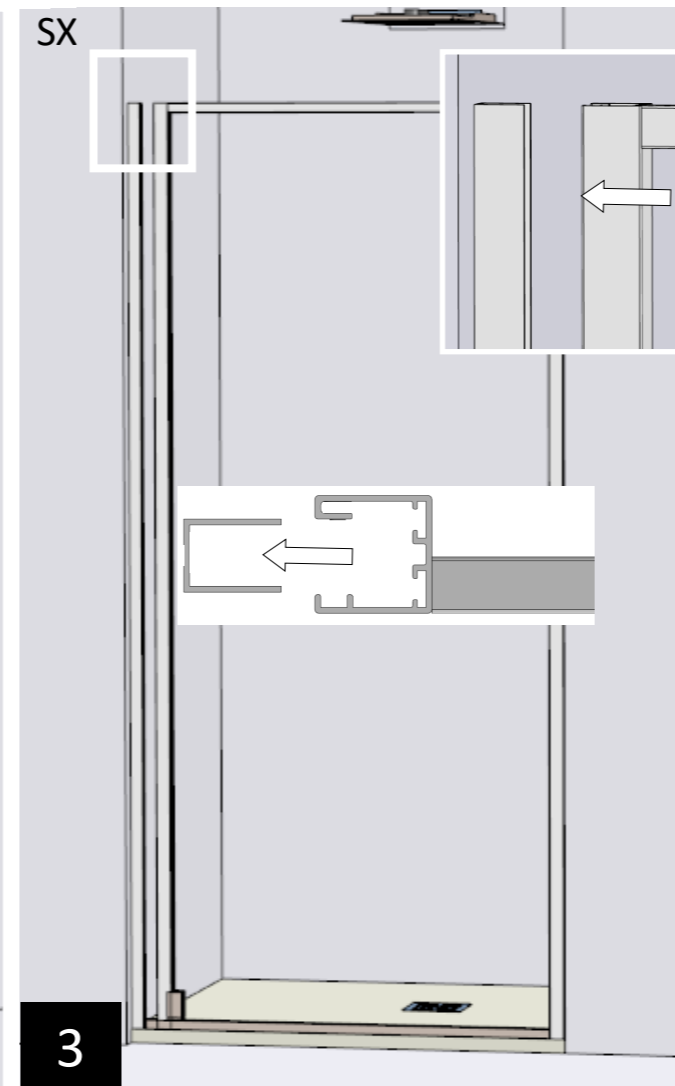
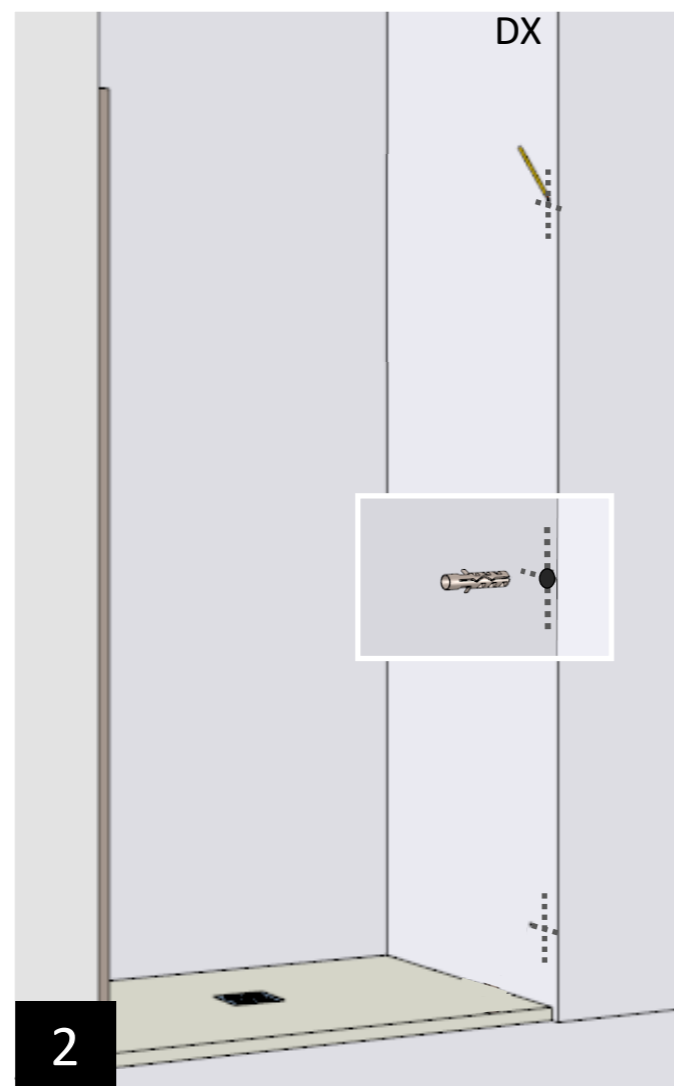
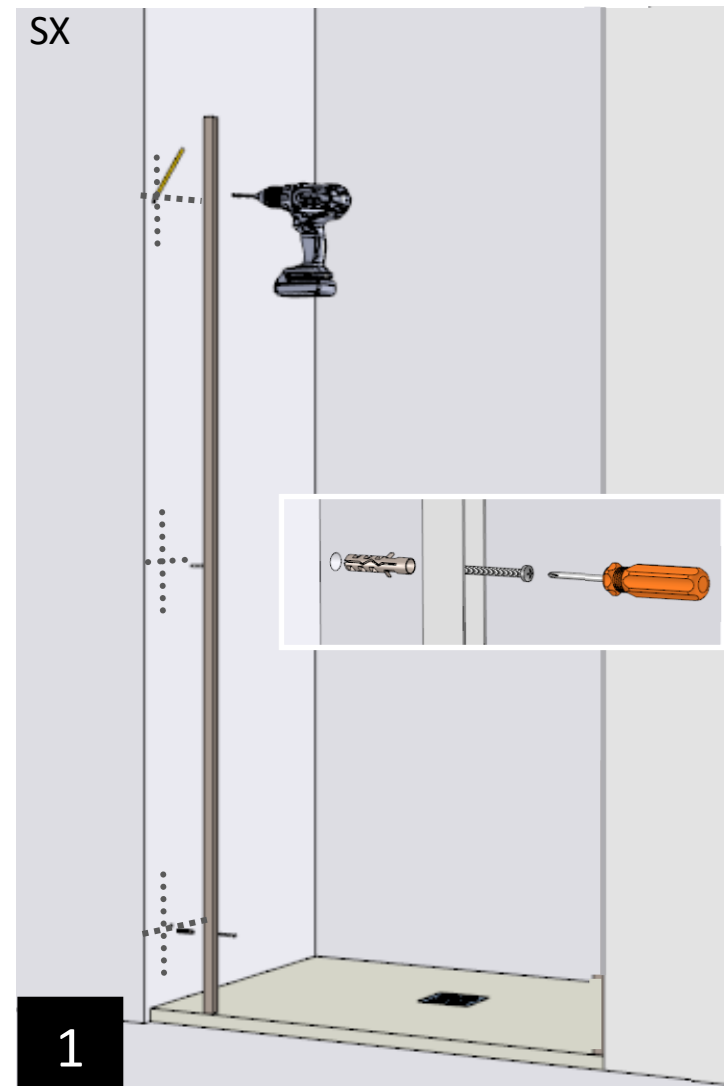

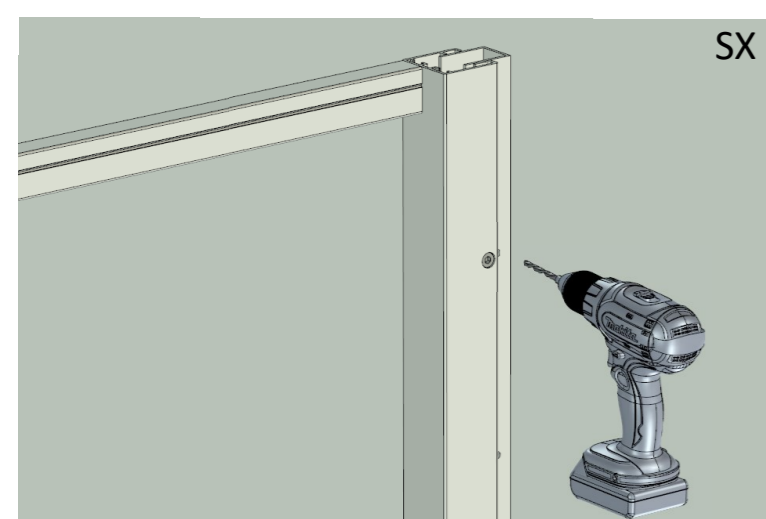

SX

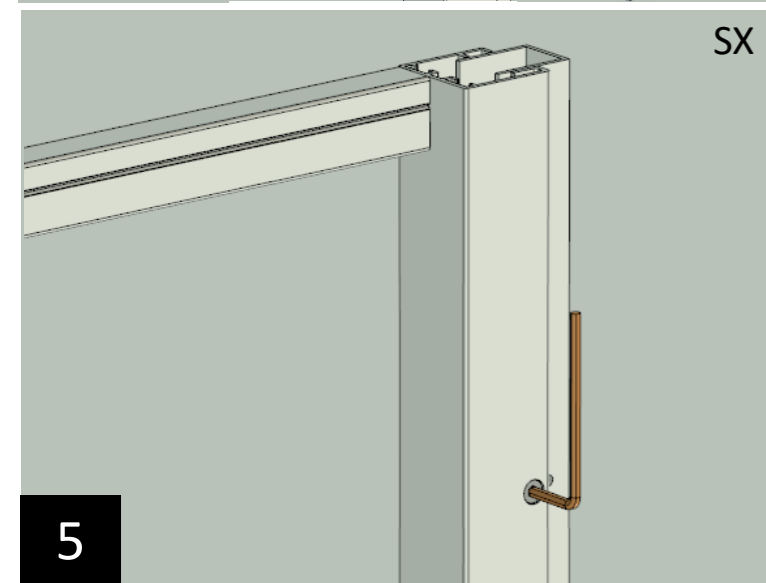

SX

5

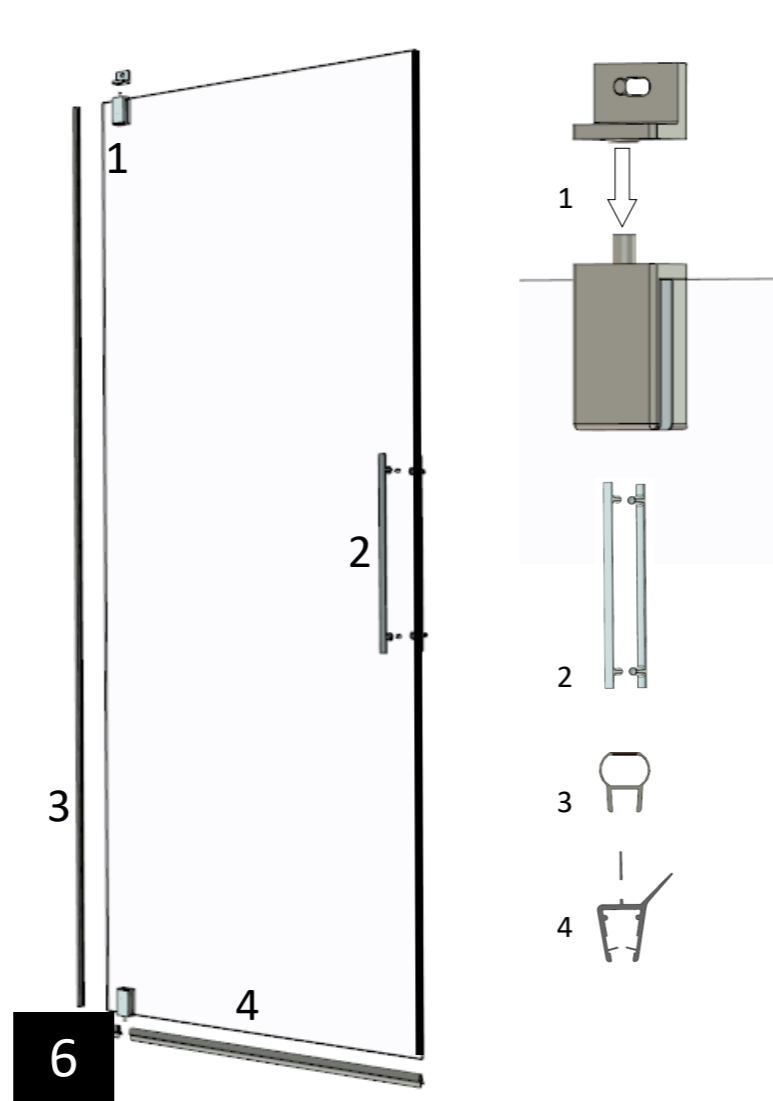

6

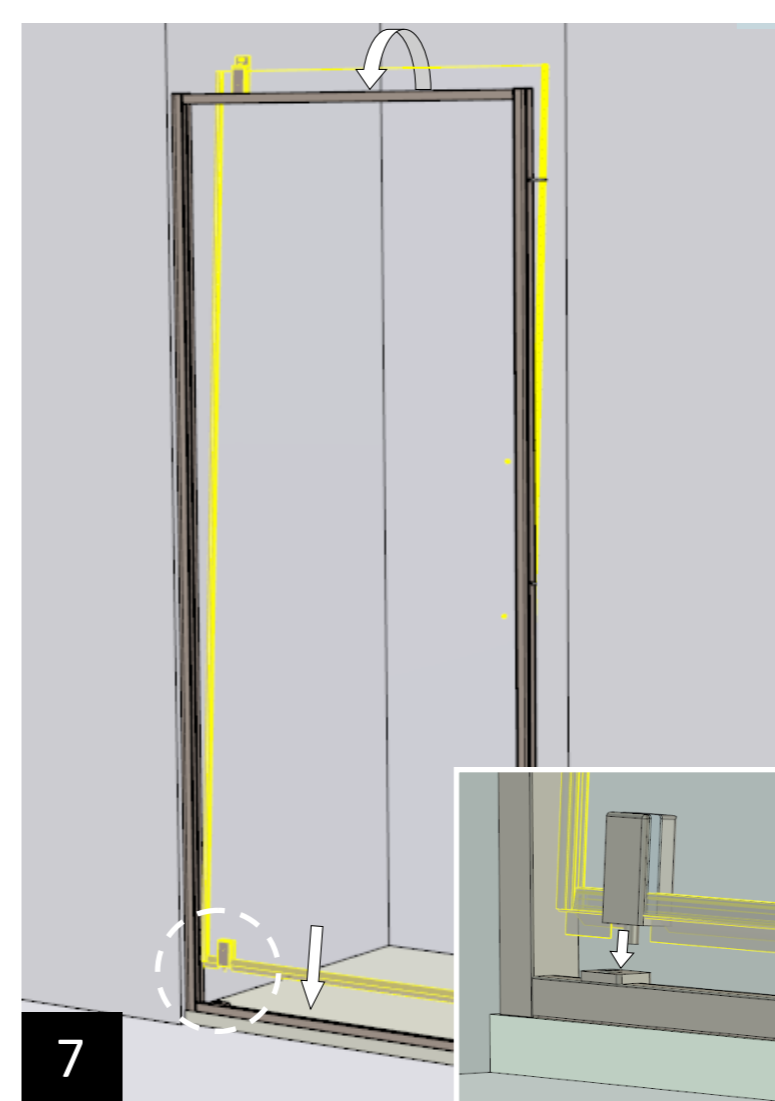

7

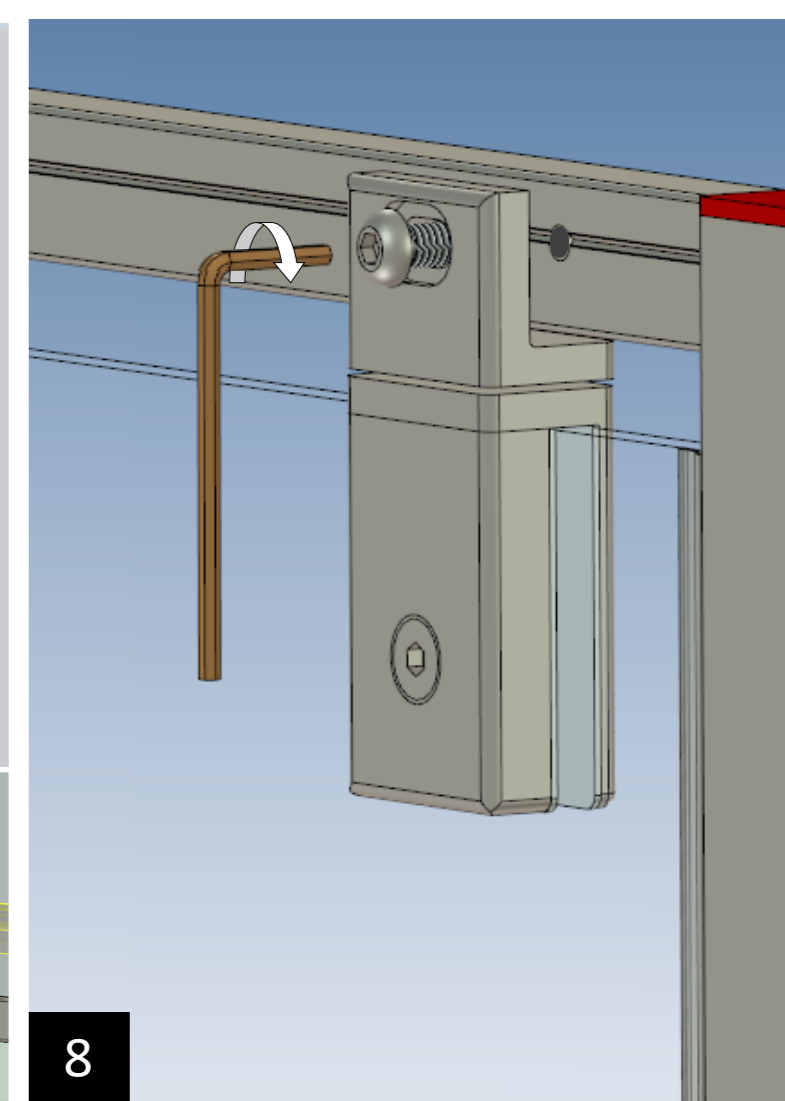

8

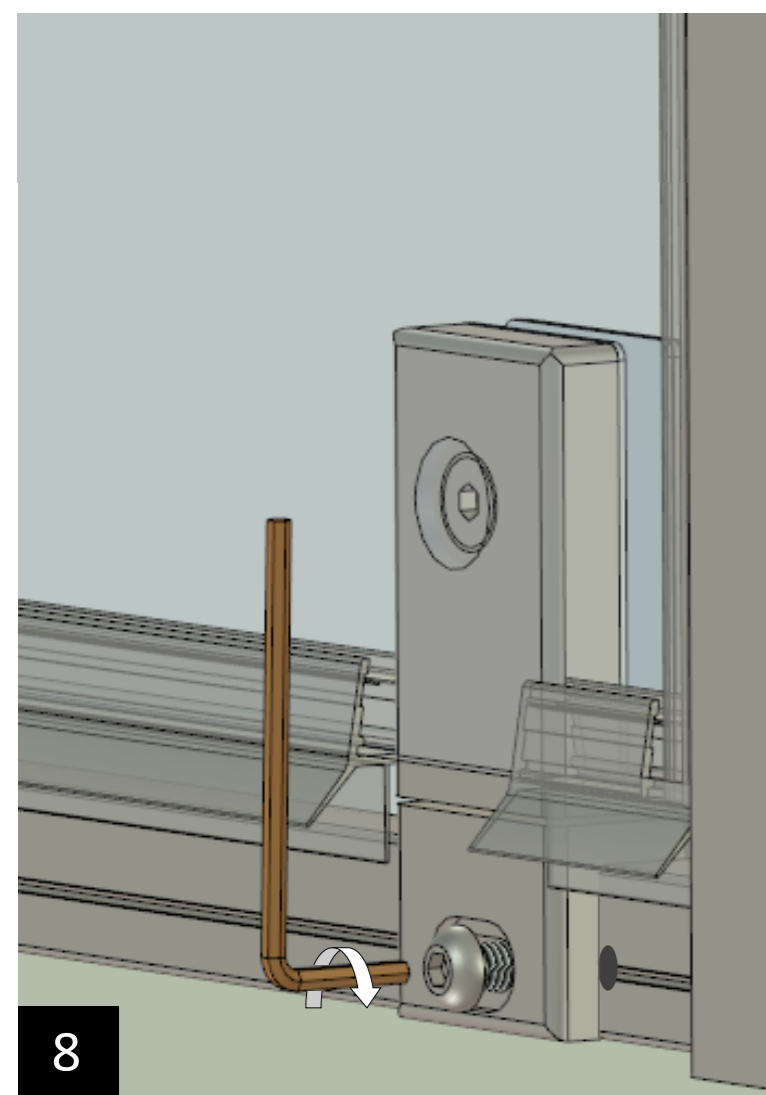

8

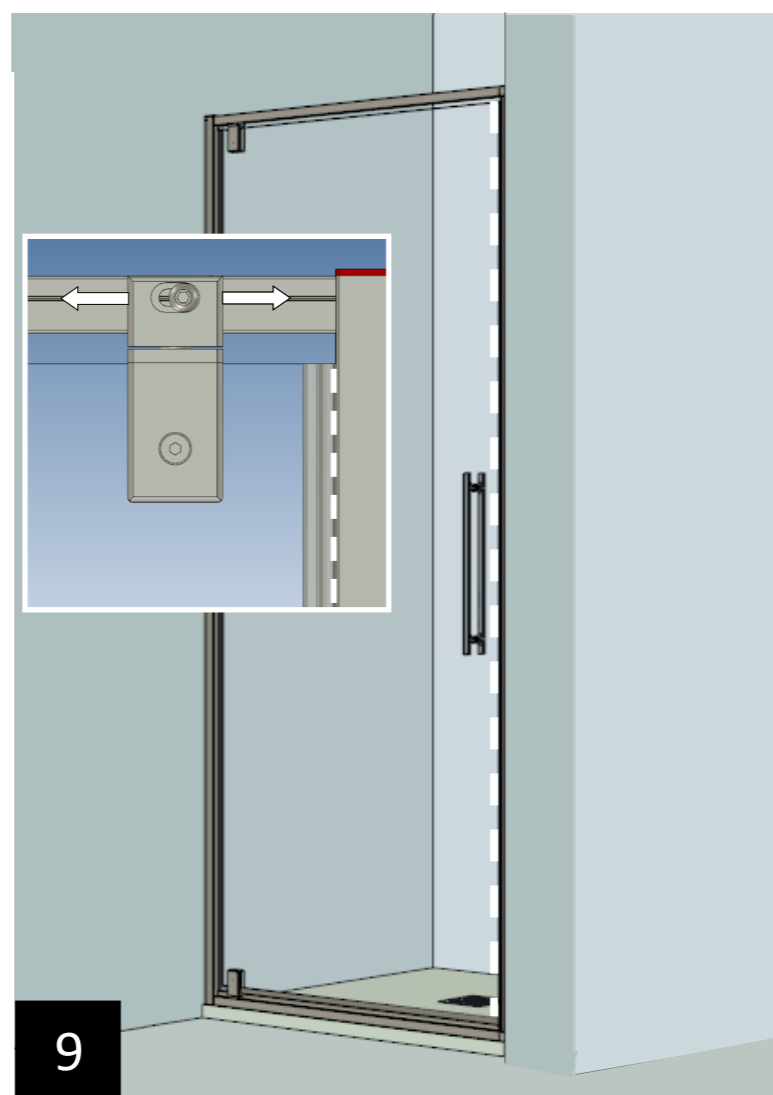

9



SILICONARE SOLO ESTERNAMENTE  
SILICON THE CABINE ONLY EXTERNALLY

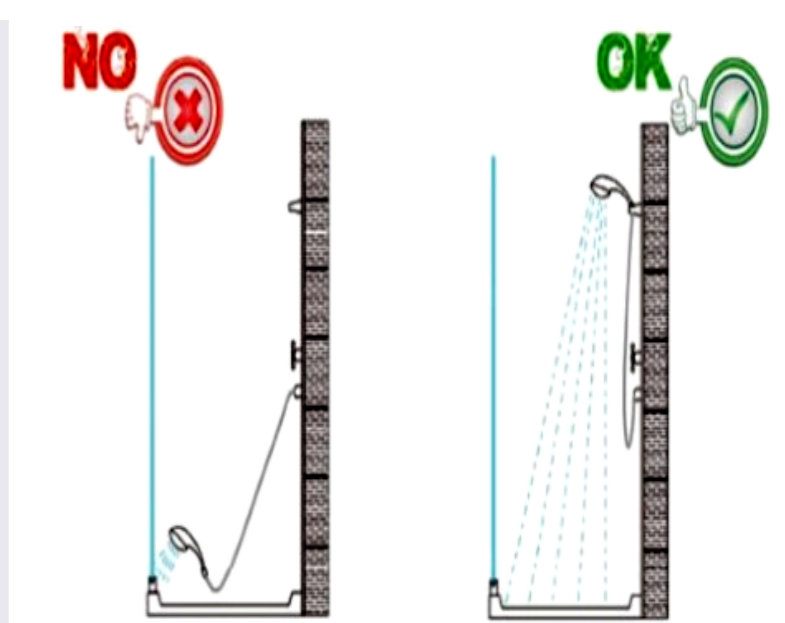

NO

OK

LA FUNZIONALITÀ DEL BOX DOCCIA  
Relativa alla tenuta dell'acqua è garantita soltanto se usata correttamente  
(come da disegno)  
THE IMPERMEABILITY OF SHOWER CABINE  
is guaranteed only if it use correctly ( as show in the picture )

**CSA** box doccia

IMPROVES YOUR LIFE  
tel. +39 0112238545  
info@csaboxdoccia.it  
www.csaboxdoccia.it