



**ATTENZIONE:** leggere

l'installazione deve essere eseguita da personale qualificato e abilitato;  
 è necessario rispettare le norme e le disposizioni di legge in fatto di sicurezza;  
 è necessario rispettare le disposizioni di installazione e manutenzione riportate sul presente manuale;  
 le istruzioni costituiscono parte integrante del prodotto pertanto deve essere conservato;  
 questo prodotto può essere destinato solo all'uso per il quale è stato progettato;

**NON UTILIZZARE APPARECCHI ELETTRICI ALL'INTERNO DELLA CABINA**

**ATTENTION:** read and follow all instructions

installation should be performed by qualified personnel;  
 it is necessary to follow all security norms and laws;  
 it is necessary to follow installation and maintenance instructions presented in this manual;  
 the instructions form the integral part of the product and therefore they should be preserved;  
 this product should be used with the scope for which it was developed.

**DO NOT USE ELECTRICAL DEVICES INSIDE OF THE CABINE**

**Componenti per l'installazione**  
Components for the installation

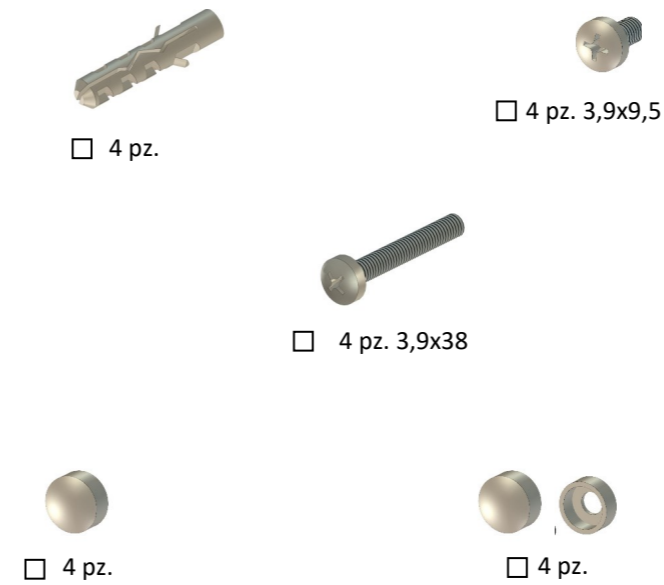

**Utensili per l'installazione**  
Tools for the installation



IMMAGINI INSERITE A SOLO SCOPO ILLUSTRATIVO  
IMAGES INSERTED FOR ILLUSTRATIVE PURPOSES ONLY

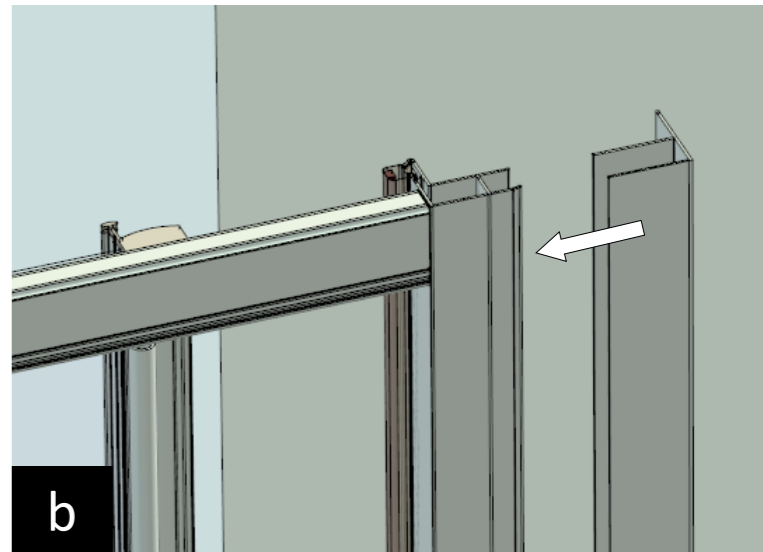
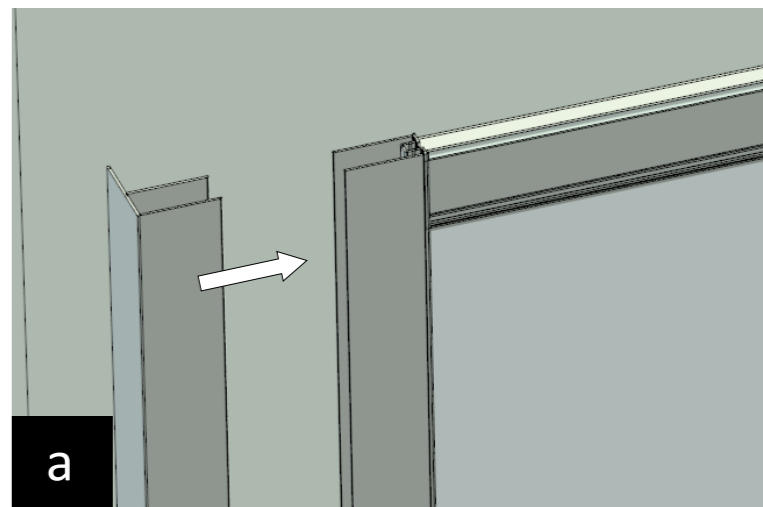
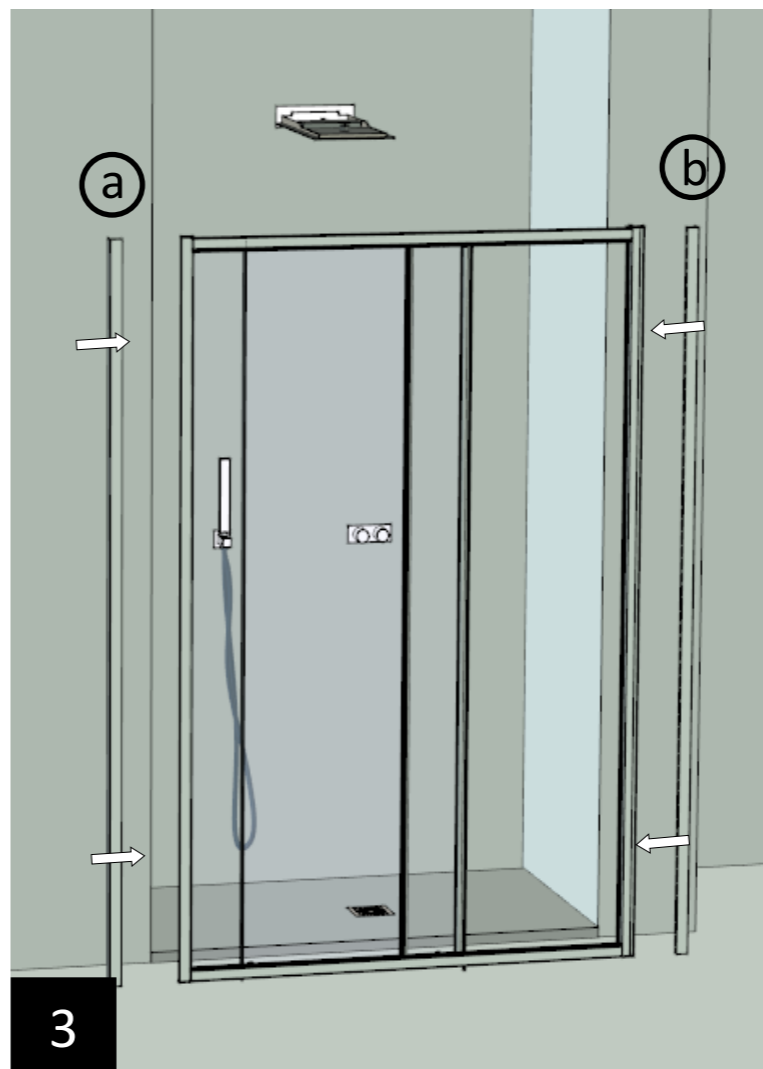
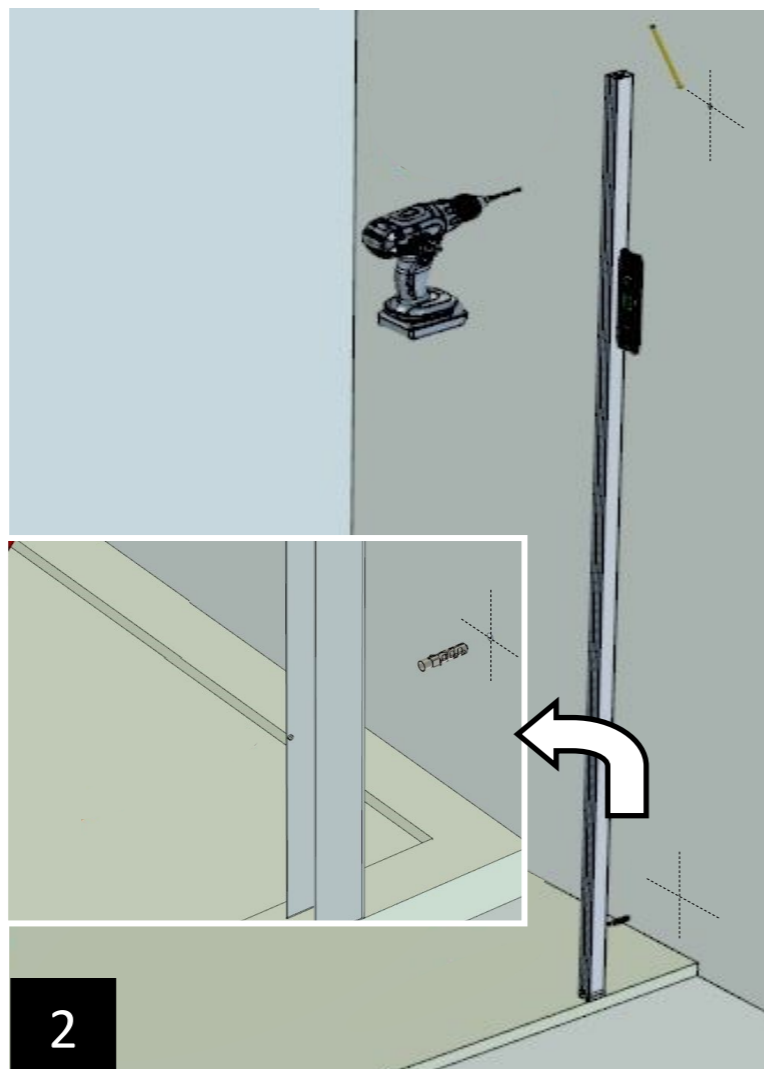
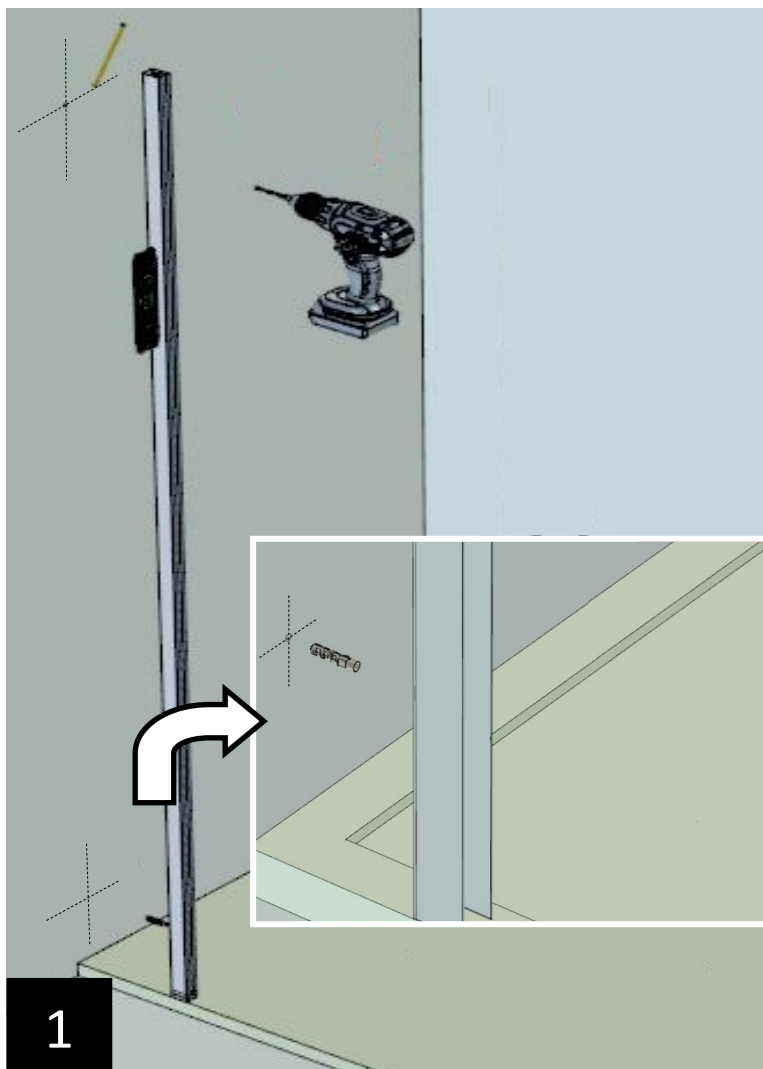

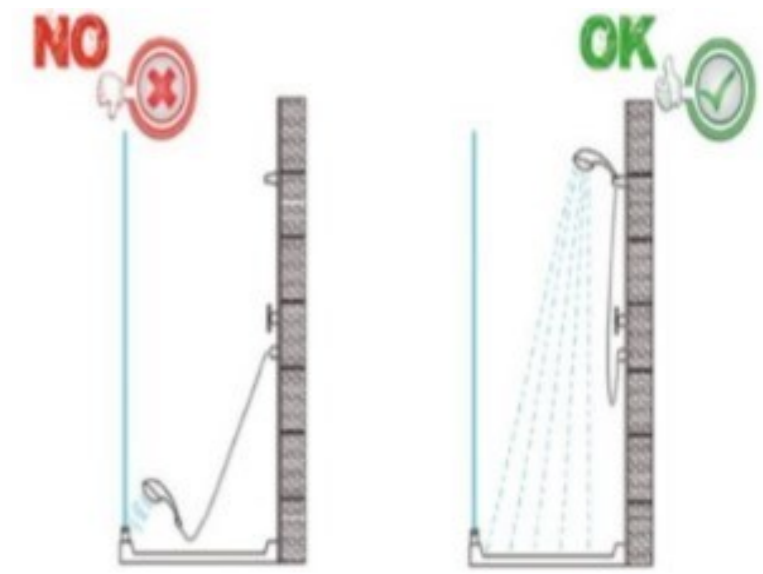
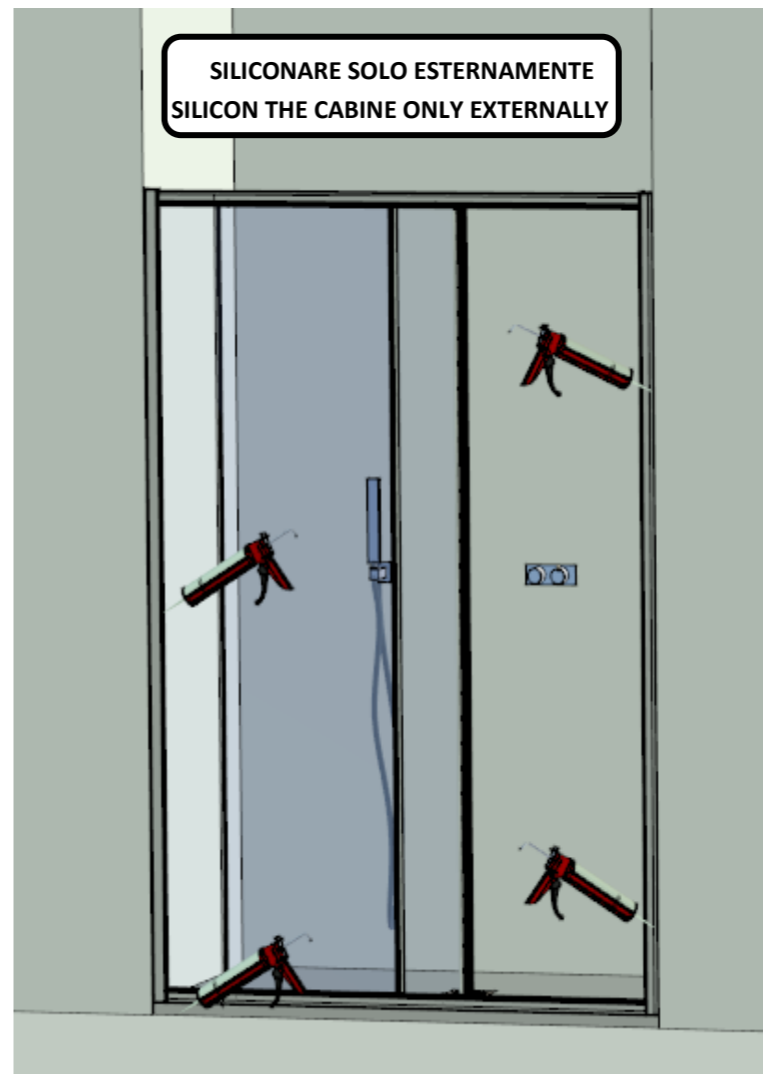
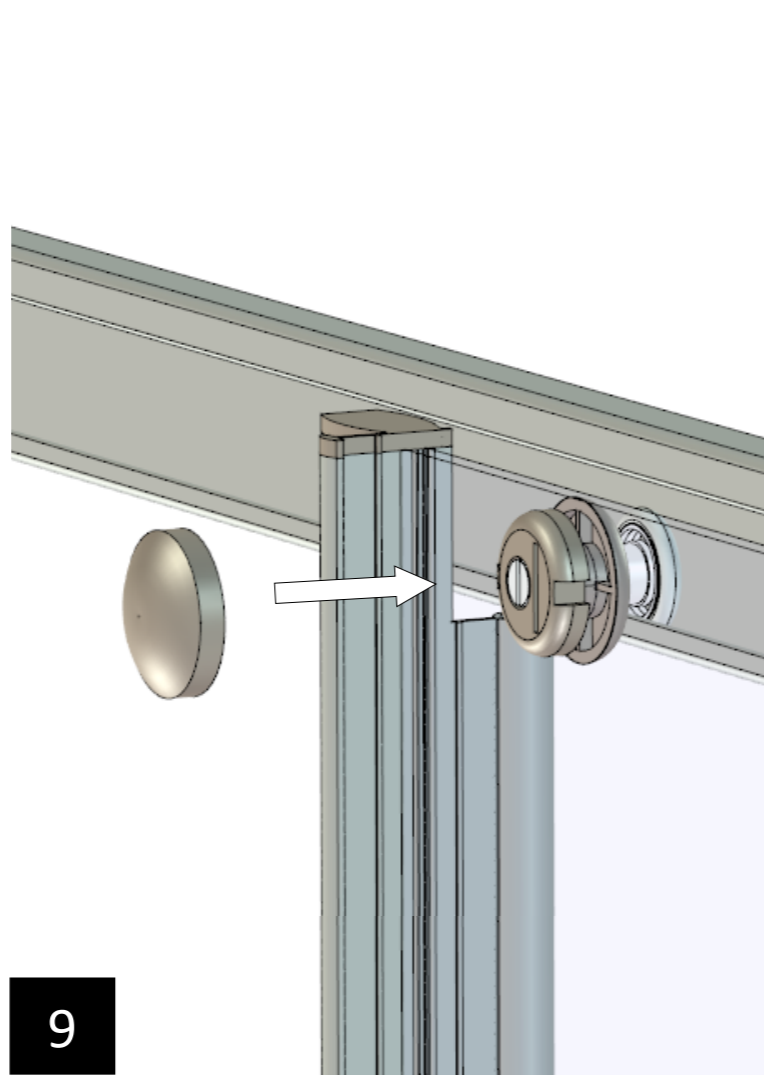
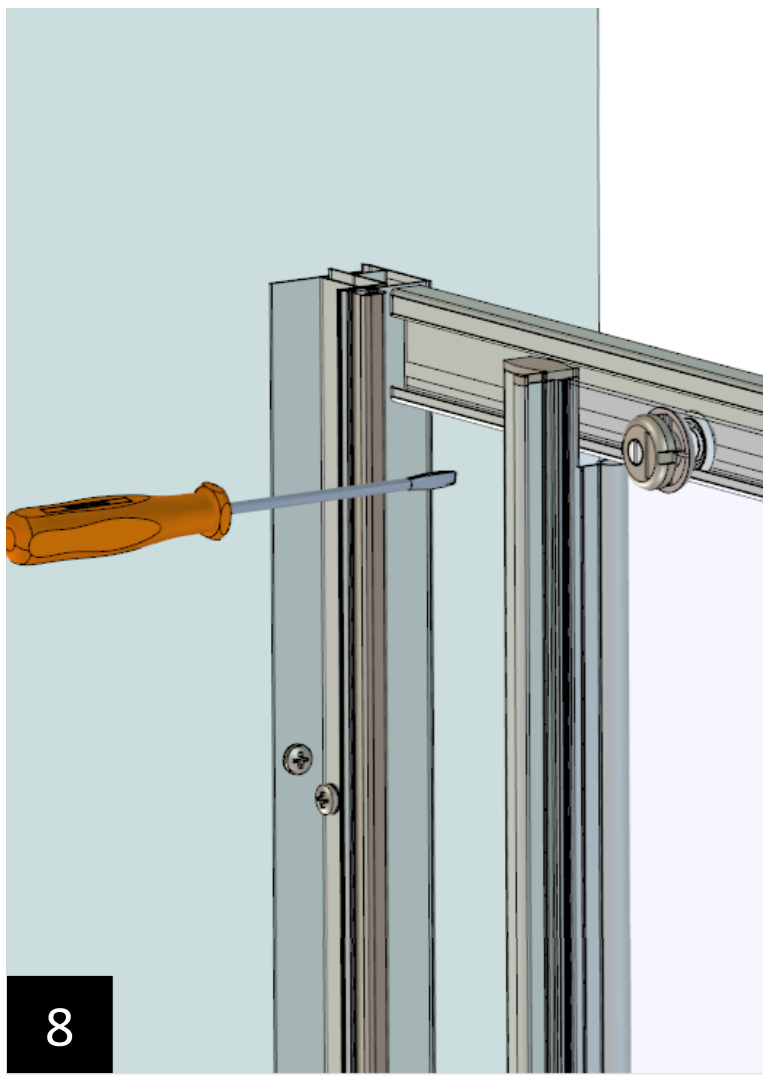
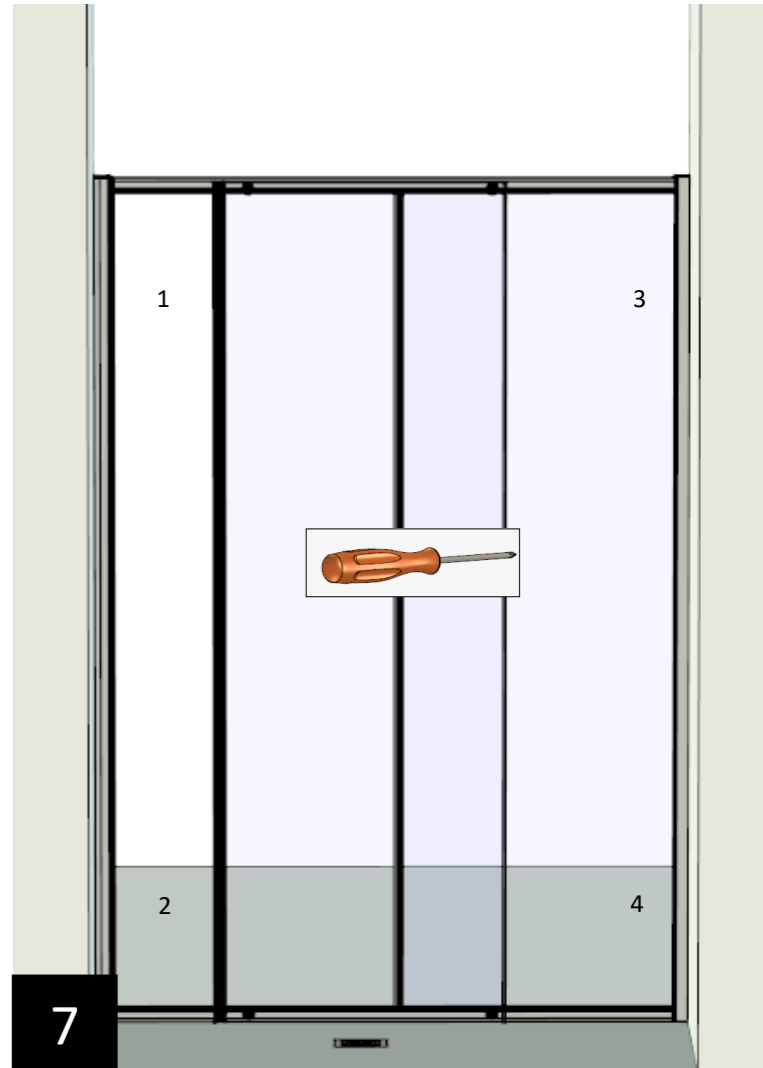
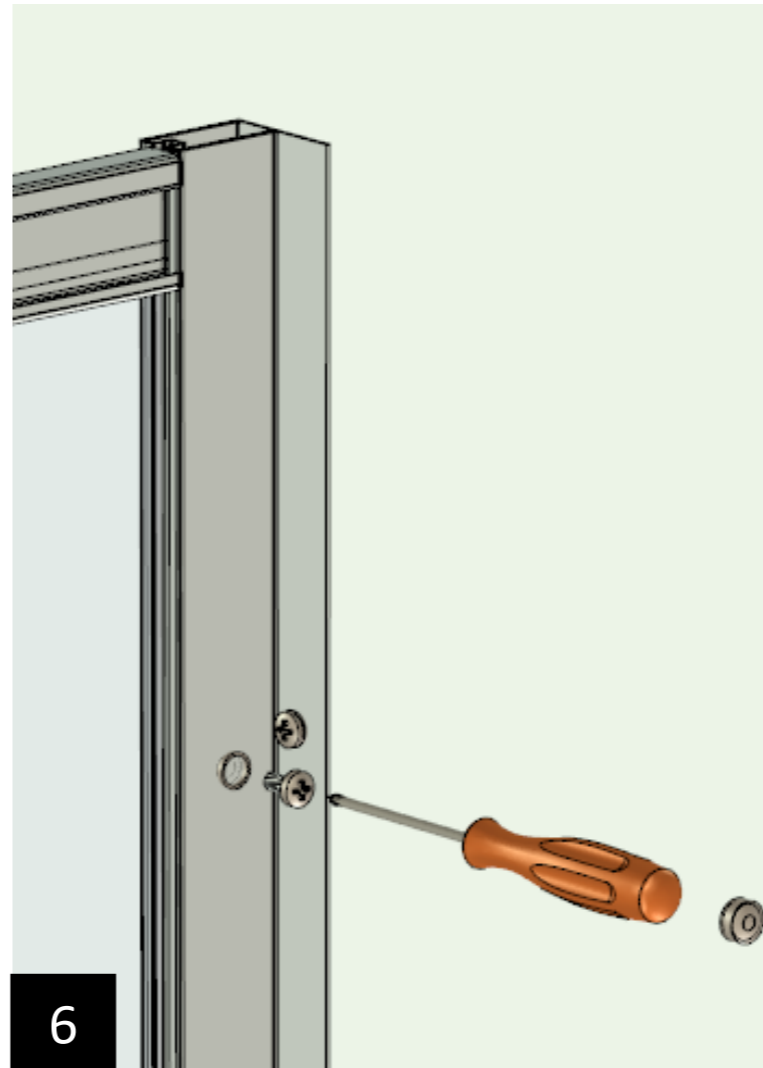
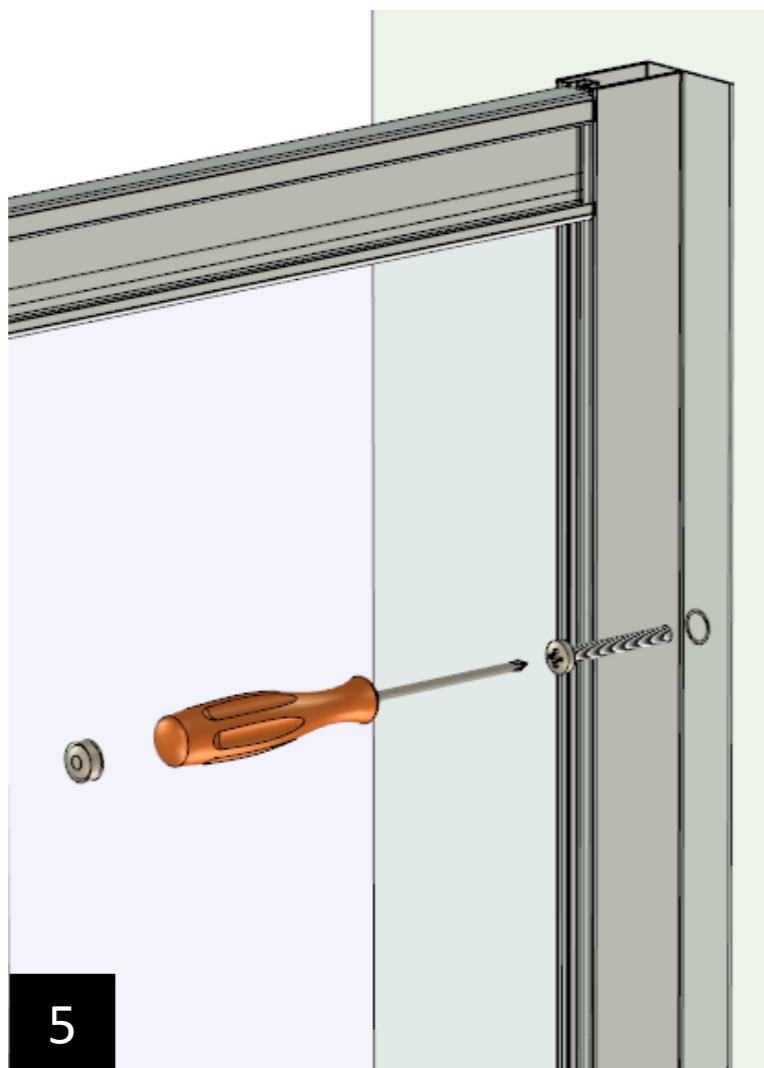
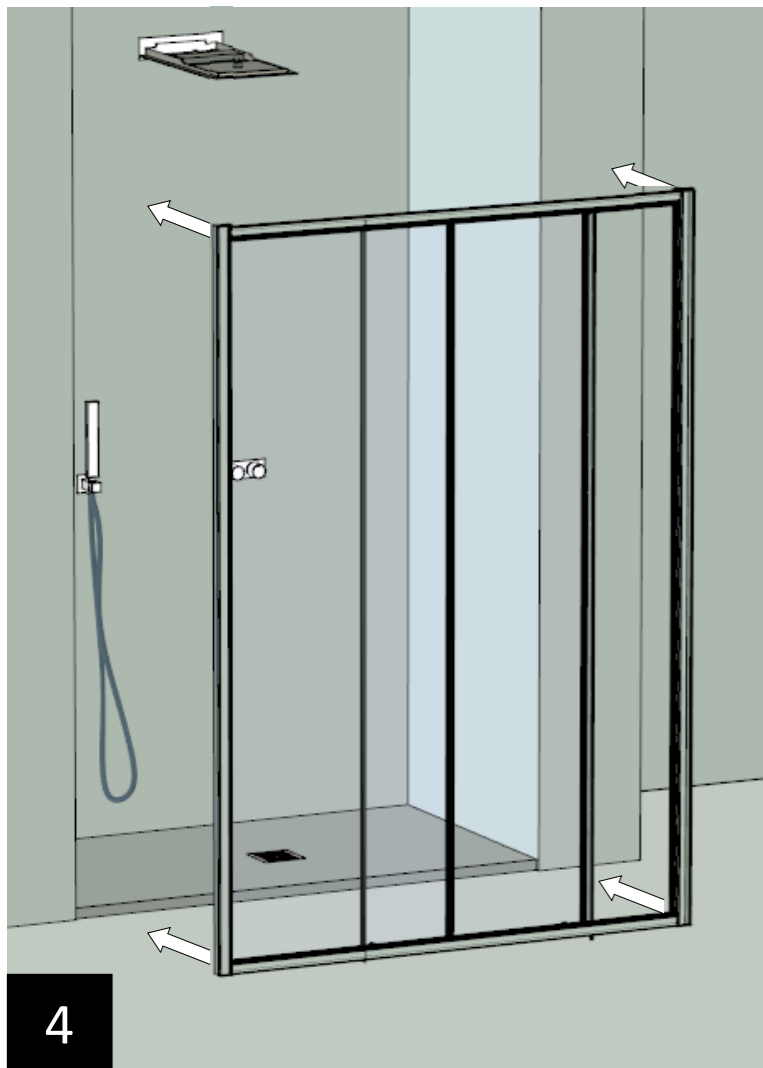

LA FUNZIONALITÀ DEL BOX DOCCIA  
Relativa alla tenuta dell'acqua è garantita soltanto se usata correttamente  
(come da disegno)

THE IMPERMEABILITY OF SHOWER CABINE  
is guaranteed only if it use correctly ( as show in the picture )

**csa** box doccia

IMPROVES YOUR LIFE  
tel. +39 0112238545  
info@csaboxdoccia.it  
www.csaboxdoccia.it